

# Product Sheet



Item No. B A H 1 2 C C 075 P 4 P 4 P 0 N

## housing / data

housing type	bolt hole castor with total brake
series	apparatus
fixing type	bolt hole
hole dimensions / hub width	12 mm Diameter / 28 mm
thickness of fixing / fork	2.00 mm / 2.00 mm
surface treatment	zinc-chromatised



## wheel / data

diameter	75 mm
wheel center	Polypropylene grey
wheel tread	Polypropylene grey
bearing	plain bearing
threadguard	no separate threadguard
hub width	28 mm
axle diameter	M 6
temperature range	-20°C - +60°C
dyn. load capacity	30 kg
test norm	DIN EN 12530

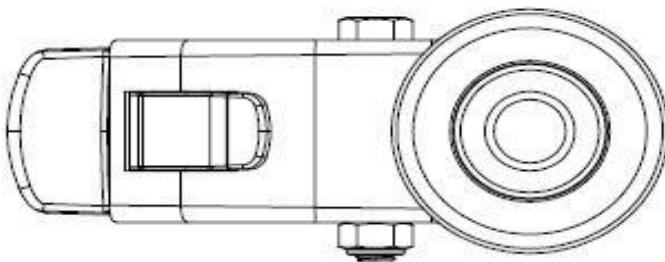
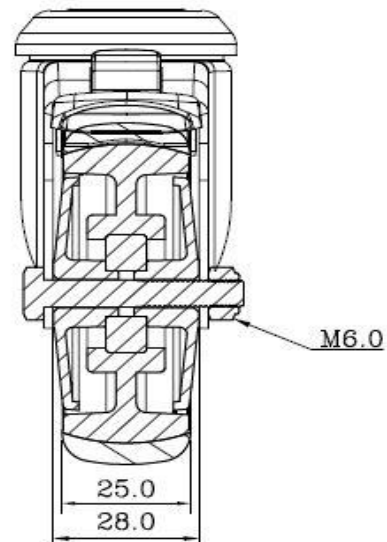
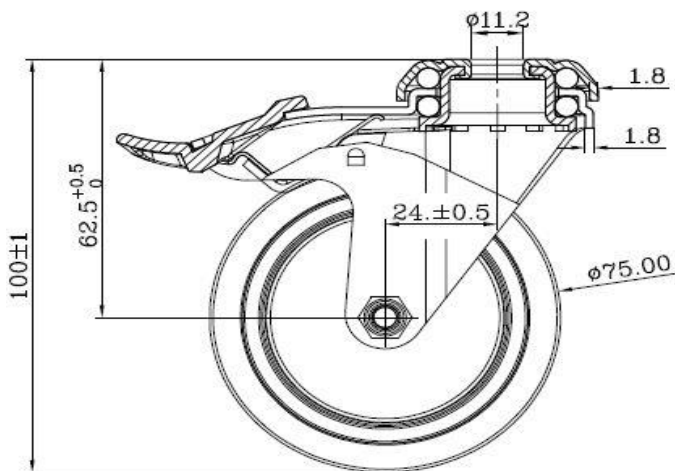

Deviation possible! All information is subject to change.