

Product Sheet



Item No. B I H 3 6 S C 100 N O N O L O N

housing / data

housing type	bolt hole castor with total brake
series	CASCOO Innovation
fixing type	bolt hole
hole dimensions / hub width	13 mm Diameter / 42 mm
thickness of fixing / fork	2.50 mm / 2.00 mm
surface treatment	Stainless steel



wheel / data

diameter	100 mm
wheel center	Polyamide white
wheel tread	Polyamide white
bearing	Plain bearing (stainless steel)
threadguard	no separate threadguard
hub width	40 mm
axle diameter	M 8
temperature range	-40°C - +80°C
dyn. load capacity	150 kg
test norm	DIN: EN 12532

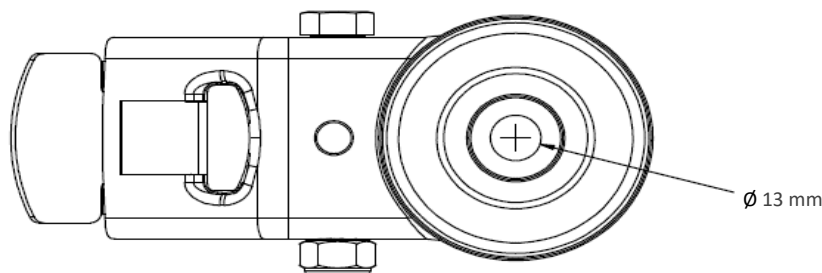
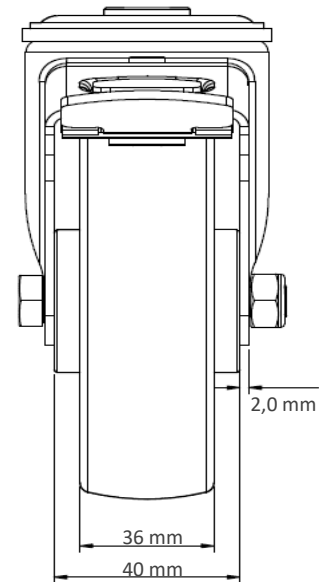
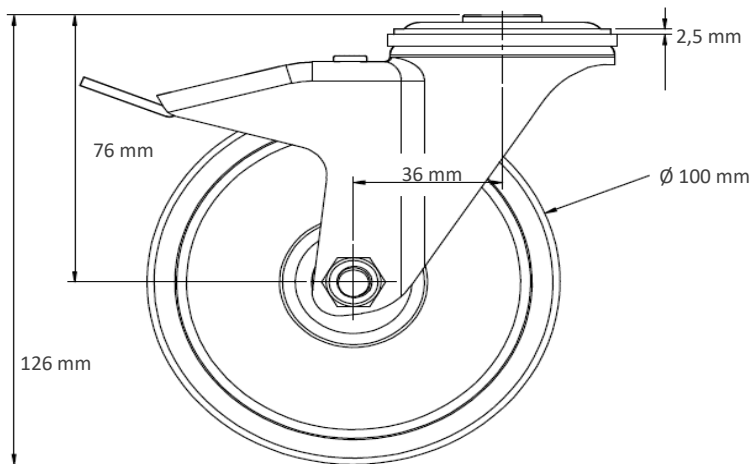
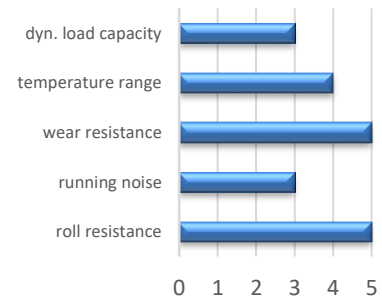

Deviation possible! All information is subject to change.