

# Product Sheet



Item No. B I H 9 O S C 160 N 2 U 6 L 0 N

## housing / data

housing type	bolt hole castor with total brake
series	CASCOO Innovation
fixing type	bolt hole
hole dimensions / hub width	13 mm Diameter / 60 mm
thickness of fixing / fork	2.75 mm / 2.50 mm
surface treatment	stainless steel



## wheel / data

diameter	160 mm
wheel center	Polyamide grey
wheel tread	Polyurethane red
bearing	plain bearing (stainless steel)
threadguard	no separate threadguard
hub width	59 mm
axle diameter	M 12
temperature range	-40°C - +80°C
dyn. load capacity	300 kg
test norm	DIN: EN 12532

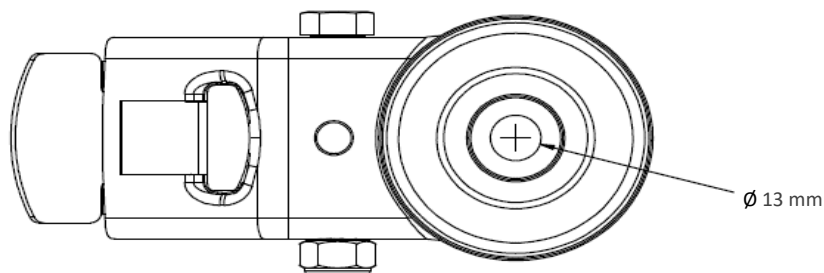
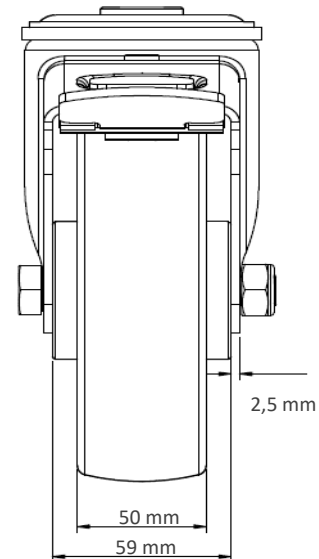
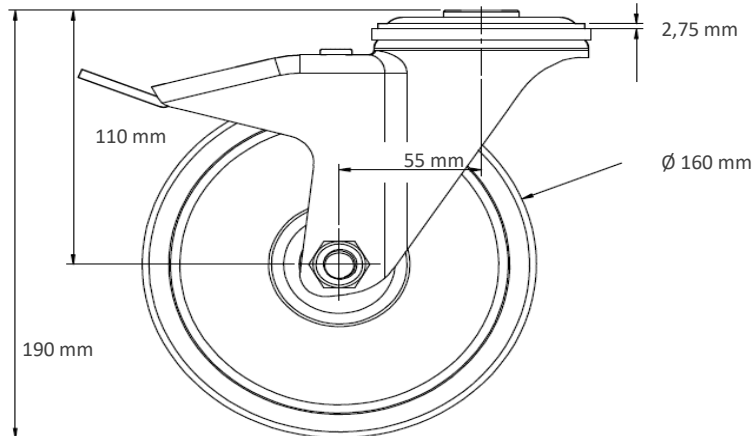
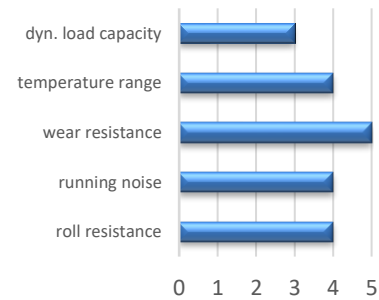

Deviation possible! All information is subject to change.