

# Product Sheet



Item No. B P H 3 5 W C 100 N 0 N 0 P 0 N

## housing / data

housing type bolt hole castor with total brake  
 series CASCOO Premium  
 fixing type bolt hole  
 hole dimensions / hub width 13 mm Diameter / 42 mm  
 thickness of fixing / fork 2.50 mm / 2.50 mm  
 surface treatment galvanized blue zinc



## wheel / data

diameter 100 mm  
 wheel center Polyamide white  
 wheel tread Polyamide white  
 bearing plain bearing  
 threadguard **no separate threadguard**  
 hub width 40 mm  
 axle diameter M 8  
 temperature range -40°C - +80°C  
 dyn. load capacity 150 kg  
 test norm DIN: EN 12532

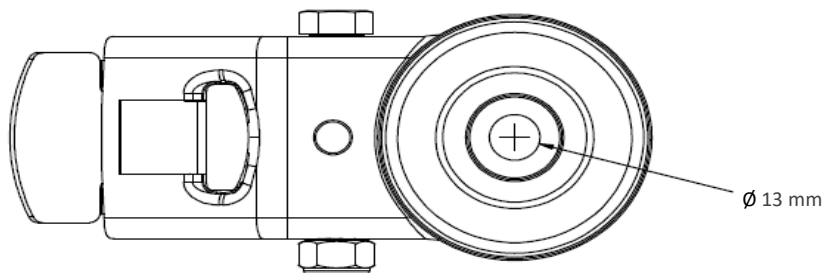
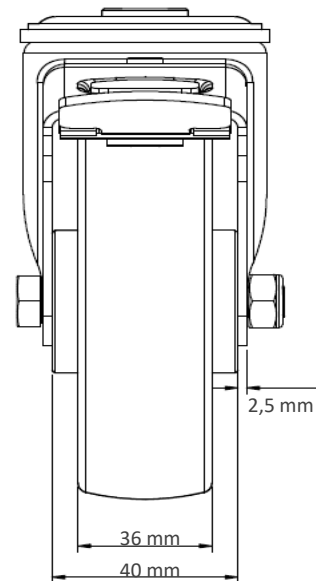
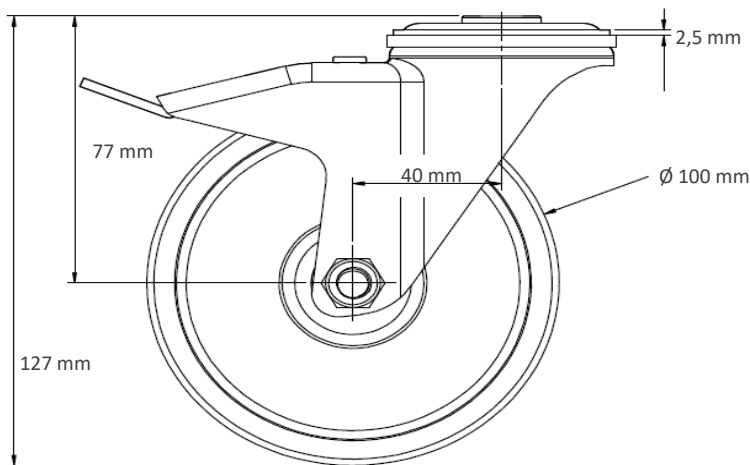
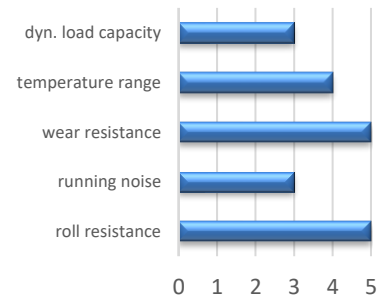

Deviation possible! All information is subject to change.