

Product Sheet



Item No. B P H 9 8 W C 200 R 4 E 1 D 3 4

housing / data

housing type bolt hole castor with total brake
 series CASCOO Premium
 fixing type bolt hole
 hole dimensions / hub width 13 mm Diameter / 60 mm
 thickness of fixing / fork 3.50 mm / 3.00 mm
 surface treatment galvanized blue zinc



wheel / data

diameter 200 mm
 wheel center Polyamide black
 wheel tread elastic 65° Shore A blue
 bearing double ball bearing
 threadguard small plastic threadguard
 hub width 60 mm
 axle diameter M 12
 temperature range -20°C - +80°C
 dyn. load capacity 250 kg
 test norm DIN EN 12532

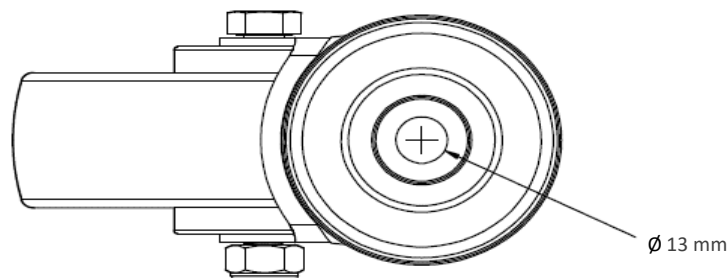
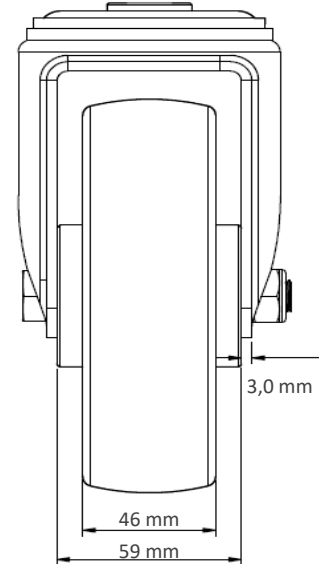
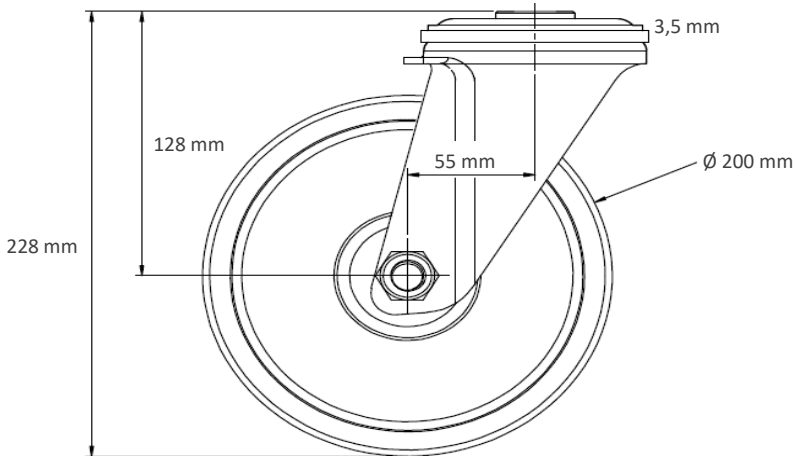
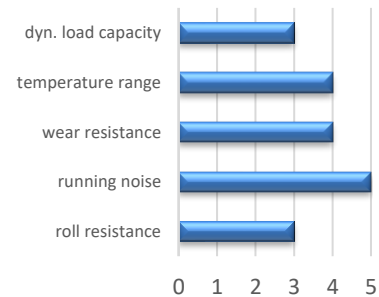

Deviation possible! All information is subject to change.