

Product Sheet



Item No. F H P 5 M W C 125 I 2 U 5 D 0 N

housing / data

housing type	swivel castor with back brake
series	heavy duty
fixing type	fixing plate
hole dimensions / hub width	105 x 80 mm / 60 mm
thickness of fixing / fork	8.00 mm / 6.00 mm
surface treatment	galvanized blue zinc



wheel / data

diameter	125 mm
wheel center	Iron rim grey
wheel tread	Polyurethane brown
bearing	double ball bearing
threadguard	no separate threadguard
hub width	60 mm
axle diameter	M 12
temperature range	-20°C - +60°C
dyn. load capacity	700 kg
test norm	DIN: EN 12533

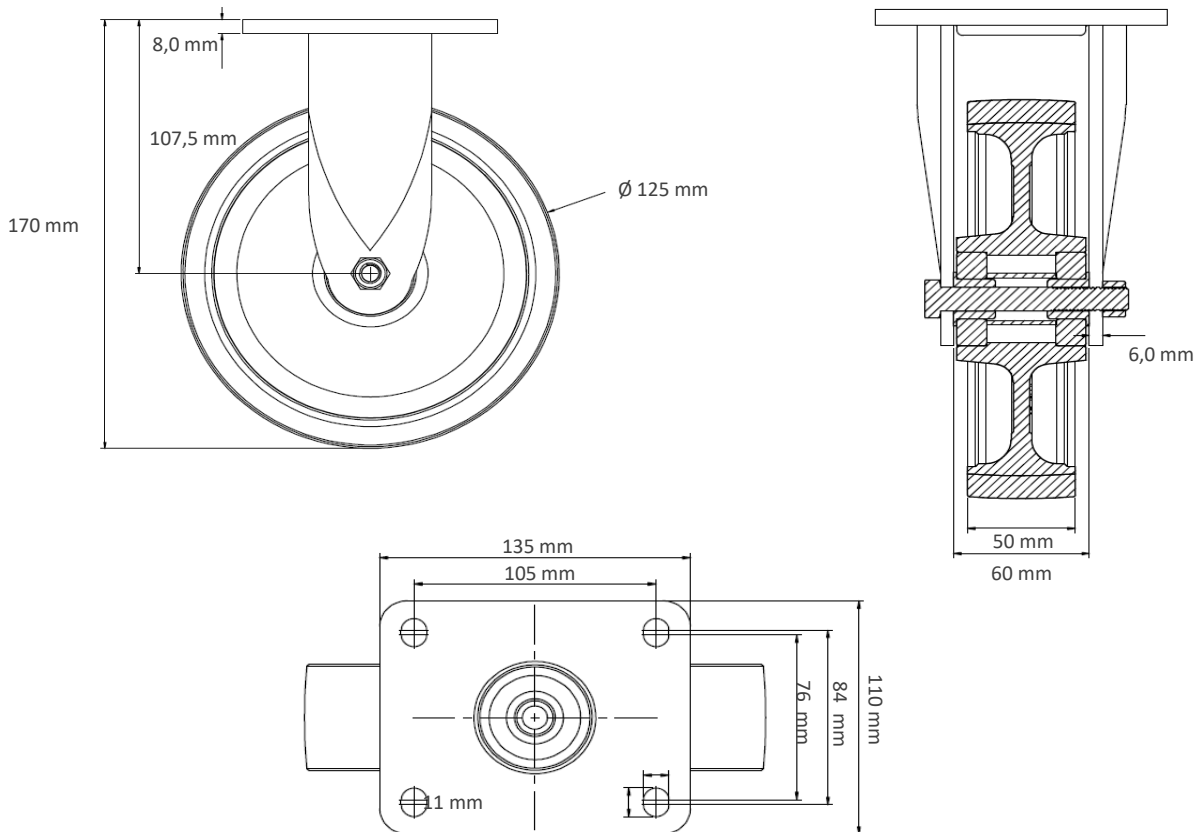
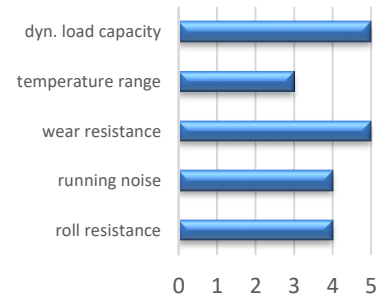

Deviation possible! All information is subject to change.