

Product Sheet



Item No. F H P K 4 W C 125 V 0 Z 0 D 0 N

housing / data

housing type	fixed castor
series	heavy duty
fixing type	fixing plate
hole dimensions / hub width	80/75x60/55 mm/48
thickness of fixing / fork	4.00 mm / 4.00 mm
surface treatment	galvanized blue zinc



wheel / data

diameter	125 mm
wheel center	Polyamide (Heavy Duty) white
wheel tread	Polyamide (Heavy Duty) white
bearing	double ball bearing
threadguard	no separate threadguard
hub width	45 mm
axle diameter	M 10
temperature range	-40°C - +80°C
dyn. load capacity	700 kg
test norm	DIN EN 12533

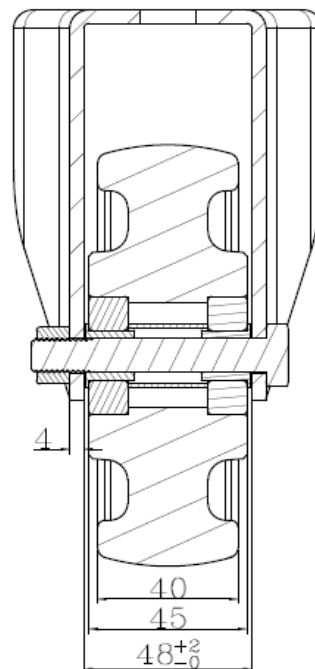
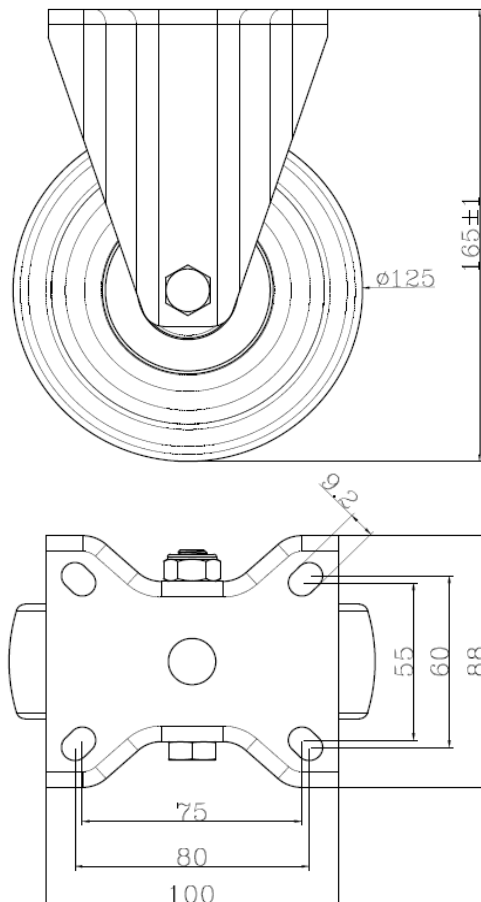

Deviation possible! All information is subject to change.