

# Product Sheet



Item No. F I P 2 2 S C 080 P 2 W 2 L 0 N

## housing / data

housing type	fixed castor
series	CASCOO Innovation
fixing type	fixing plate
hole dimensions / hub width	80 x 60 mm / 42 mm
thickness of fixing / fork	2.00 mm / 2.00 mm
surface treatment	stainless steel



## wheel / data

diameter	80 mm
wheel center	Polypropylene grey
wheel tread	thermopl. rubber 95° Shore A grey
bearing	plain bearing (stainless steel)
threadguard	no separate threadguard
hub width	40 mm
axle diameter	M8
temperature range	-20°C - +60°C
dyn. load capacity	80 kg
test norm	DIN EN 12532

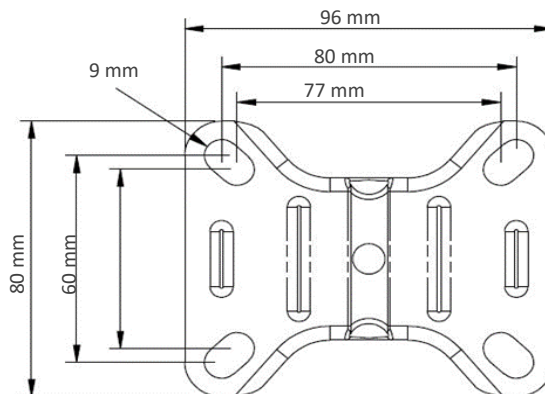
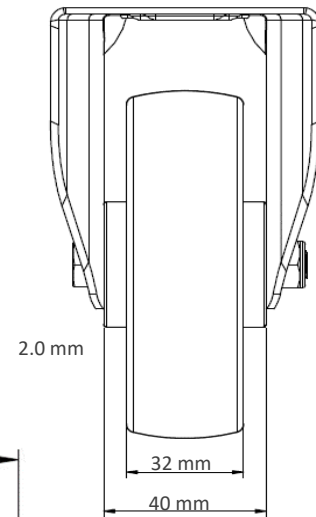
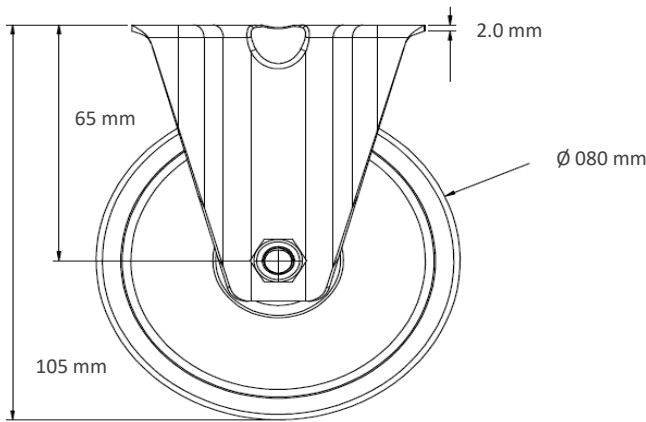
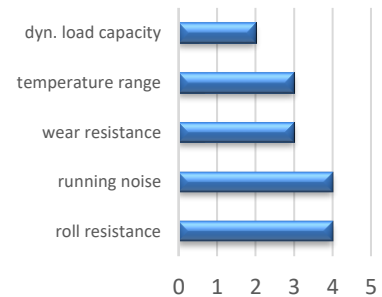

**Deviation possible! All information is subject to change.**