

Product Sheet



Item No. F I P 2 2 S C 100 N 0 N 0 L 0 N

housing / data

housing type	fixed castor
series	CASCOO Innovation
fixing type	fixing plate
hole dimensions / hub width	80 x 60 mm / 42 mm
thickness of fixing / fork	2.00 mm / 2.00 mm
surface treatment	stainless steel



wheel / data

diameter	100 mm
wheel center	Polyamide
wheel tread	Polyamide
bearing	plain bearing (stainless steel)
threadguard	no separate threadguard
hub width	40 mm
axle diameter	M8
temperature range	-40°C - +80°C
dyn. load capacity	150 kg
test norm	DIN: EN 12532

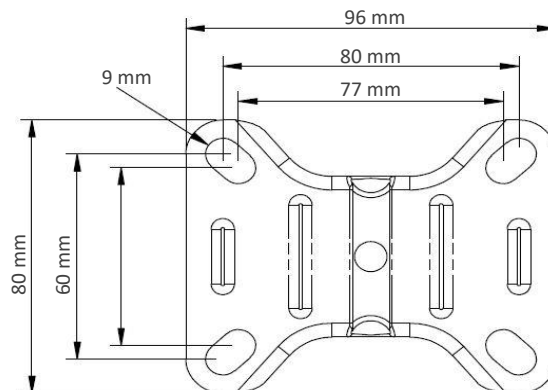
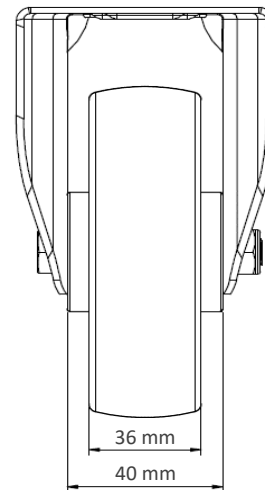
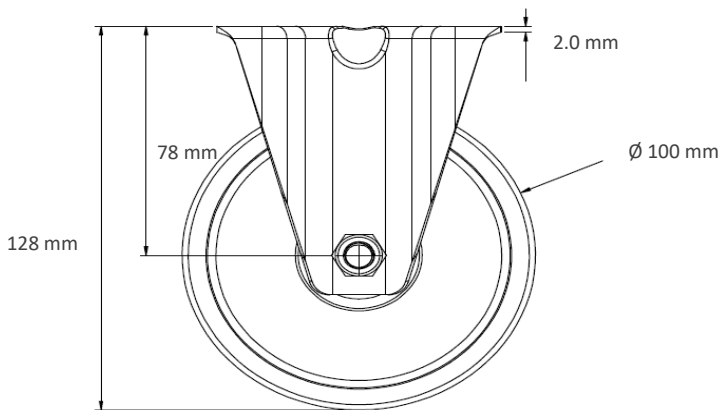
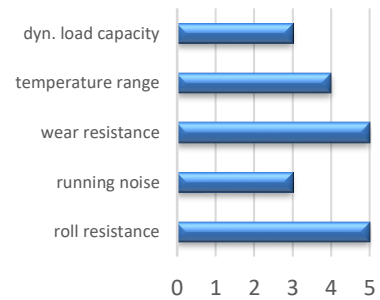

Deviation possible! All information is subject to change.