

Product Sheet



Item No. F I P 2 2 S C 100 R 4 E 2 Q 0 N

housing / data

housing type fixed castor
 series CASCOO Innovation
 fixing type fixing plate
 hole dimensions / hub width 80 x 60 mm / 42 mm
 thickness of fixing / fork 2.00 mm / 2.00 mm
 surface treatment stainless steel



wheel / data

diameter 100 mm
 wheel center Polyamide black
 wheel tread elastic 65° Shore A grey
 bearing roller bearing (stainless steel)
 threadguard no separate threadguard
 hub width 40 mm
 axle diameter M 8
 temperature range -20°C - +80°C
 dyn. load capacity 150 kg
 test norm DIN EN 12532

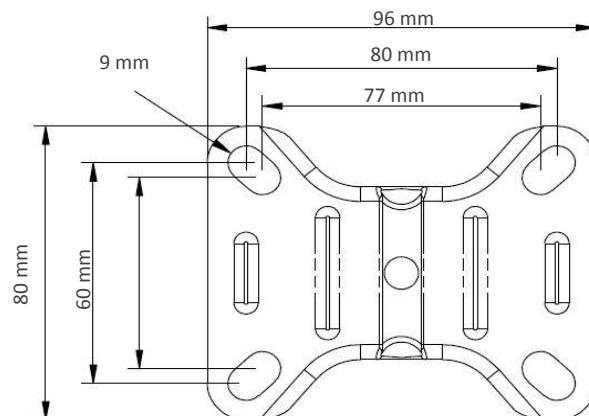
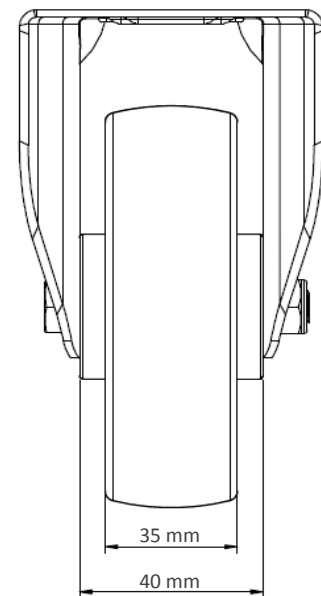
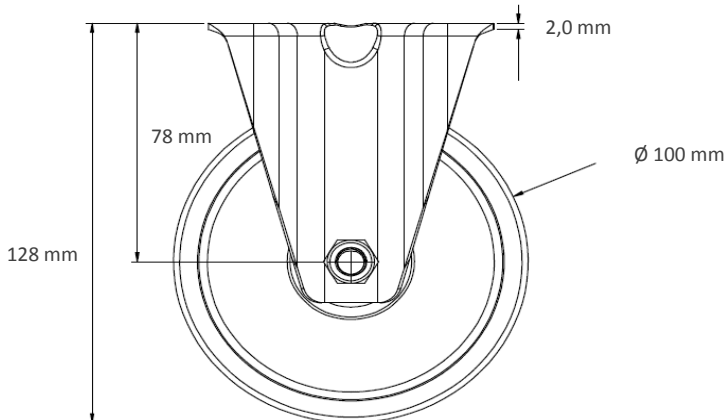
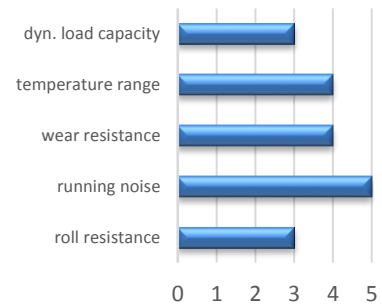

Deviation possible! All information is subject to change.