

Product Sheet



Item No. F P P 3 3 W C 125 A A E 2 D 0 N

housing / data

housing type	fixed castor
series	CASCOO Premium
fixing type	fixing plate
hole dimensions / hub width	80 x 60 mm / 52 mm
thickness of fixing / fork	3.00 mm / 3.00 mm
surface treatment	galvanized blue zinc



wheel / data

diameter	125 mm
wheel center	Aluminium
wheel tread	elastic 65° Shore A grey
bearing	double ball bearing
threadguard	no separate threadguard
hub width	50 mm
axle diameter	M 10
temperature range	-20°C - +85°C
dyn. load capacity	250 kg
test norm	DIN: EN 12532

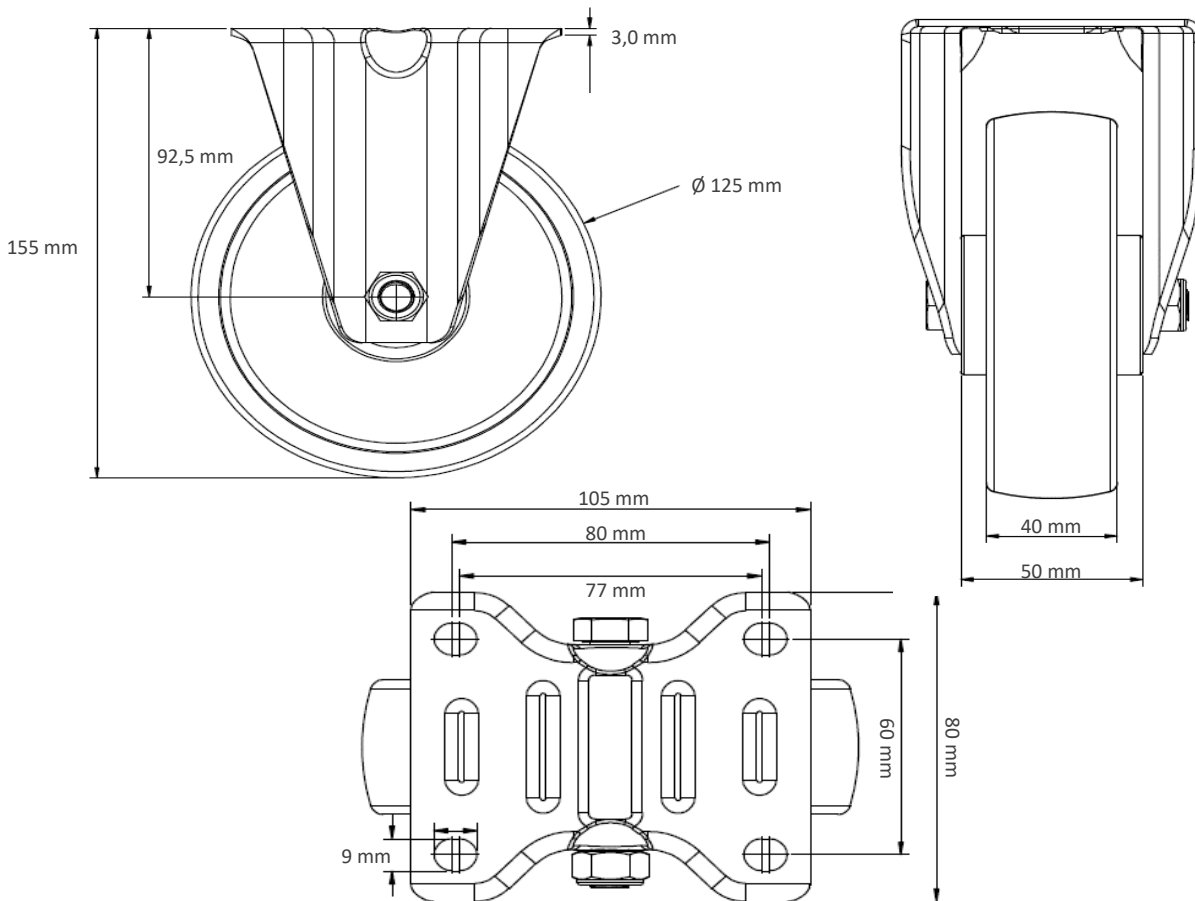
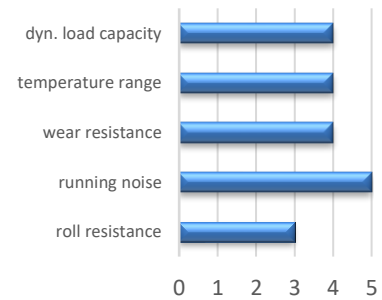

Deviation possible! All information is subject to change.