

Product Sheet



Item No. F P P 5 3 W C 200 N 2 U 6 R 1 W

housing / data

housing type	fixed castor
series	CASCOO Premium
fixing type	fixing plate
hole dimensions / hub width	105 x 80 mm / 60 mm
thickness of fixing / fork	3.00 mm / 3.00 mm
surface treatment	galvanized blue zinc



wheel / data

diameter	200 mm
wheel center	Polyamide grey
wheel tread	Polyurethane red
bearing	roller bearing
threadguard	small metal threadguard
hub width	60 mm
axle diameter	M 12
temperature range	-40°C - +80°C
dyn. load capacity	350 kg
test norm	DIN: EN 12532

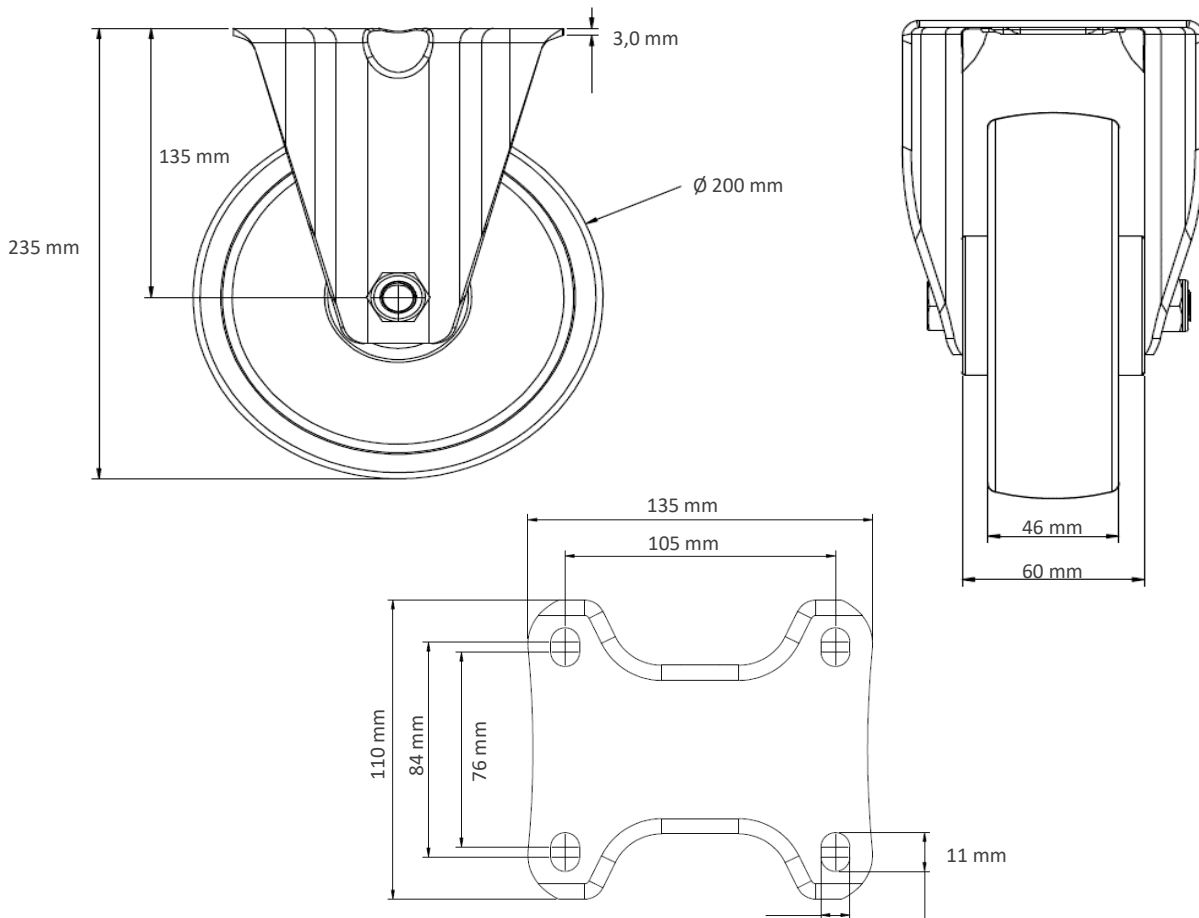
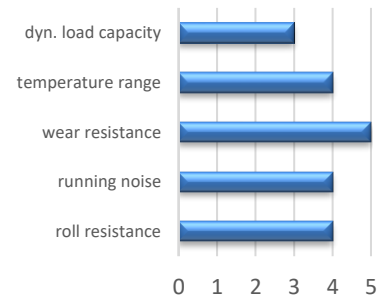

Deviation possible! All information is subject to change.