

Product Sheet



Item No. F P P 5 5 W C 160 P 2 V 2 B 3 2

housing / data

housing type fixed castor
 series CASCOO Premium
 fixing type fixing plate
 hole dimensions / hub width 105 x 80 mm / 60 mm
 thickness of fixing / fork 2.50 mm / 2.50 mm
 surface treatment galvanized blue zinc



wheel / data

diameter 160 mm
 wheel center Polypropylene grey
 wheel tread thermopl. rubber 85° Shore A grey
 bearing single ball bearing
 threadguard small plastic threadguard
 hub width 60 mm
 axle diameter M 12
 temperature range -20°C - +60°C
 dyn. load capacity 200 kg
 test norm DIN EN 12532

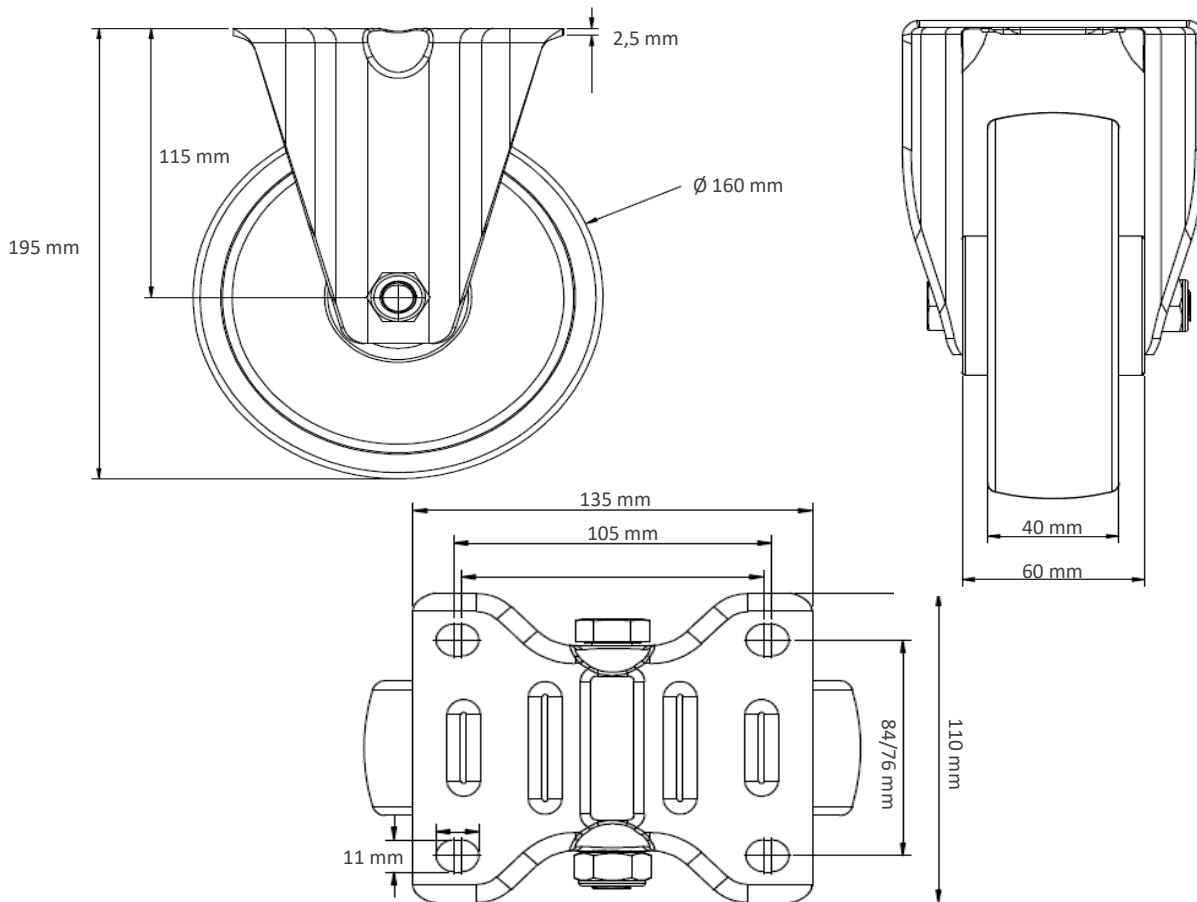
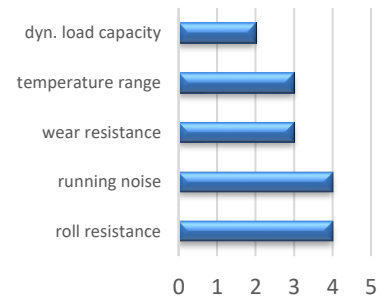

Deviation possible! All information is subject to change.