

# Product Sheet



Item No. H D H H H C 0 050 P 2 T 2 P 0 N

### housing / data

housing type swivel castor with hole fitting  
 series apparatus twin wheels  
 fixing type bolt hole  
 hole dimensions / hub width 11 mm Diameter / 44 mm  
 thickness of fixing / fork 1.50 mm / 2.00 mm  
 surface treatment zinc-chromatised



### wheel / data

diameter 50 mm  
 wheel center Polypropylene grey  
 wheel tread thermopl. rubber 95° Shore A grey  
 bearing plain bearing  
 threadguard no separate threadguard  
 hub width 44 mm  
 axle diameter M6  
 temperature range -20°C - +60°C  
 dyn. load capacity 70 kg  
 test norm DIN EN 12530

Picture with Threadguard

Wheel as 050P2T2PON:

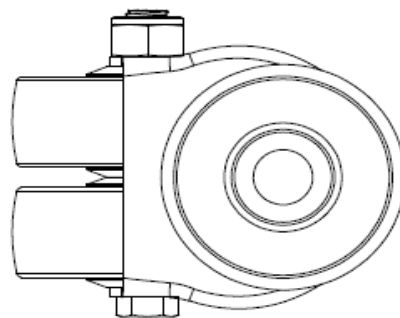
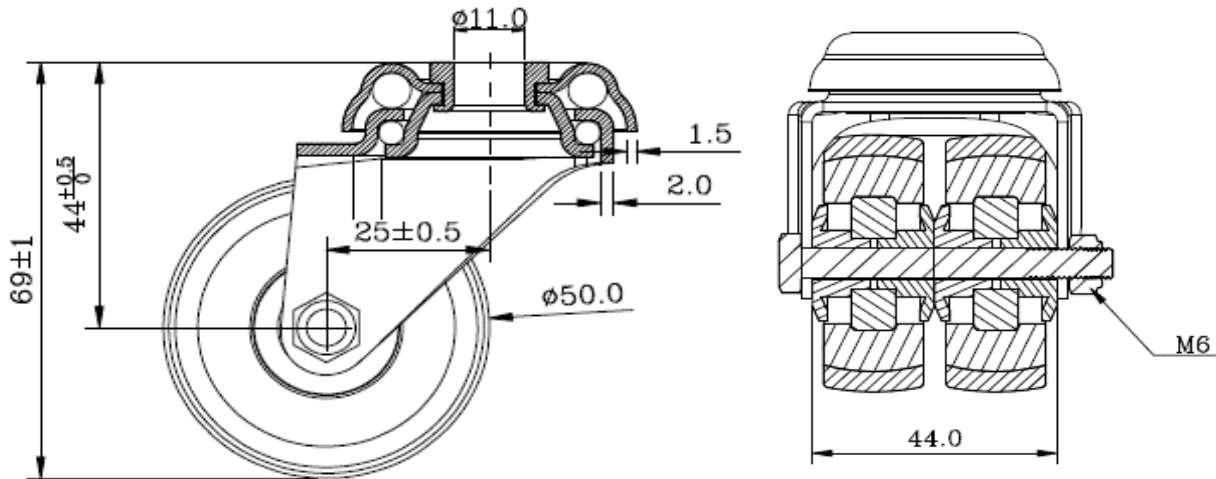

Deviation possible! All information is subject to change.