

Product Sheet



Item No. S P P 3 7 W C 100 A A E 2 D 0 N

housing / data

| | |
|-----------------------------|----------------------|
| housing type | swivel castor |
| series | CASCOO Premium |
| fixing type | fixing plate |
| hole dimensions / hub width | 80 x 60 mm / 52 mm |
| thickness of fixing / fork | 4.00 mm / 3.00 mm |
| surface treatment | galvanized blue zinc |



wheel / data

| | |
|--------------------|--------------------------|
| diameter | 100 mm |
| wheel center | Aluminium |
| wheel tread | elastic 65° Shore A grey |
| bearing | double ball bearing |
| threadguard | no separate threadguard |
| hub width | 50 mm |
| axle diameter | M 8 |
| temperature range | -20°C - +85°C |
| dyn. load capacity | 200 kg |
| test norm | DIN: EN 12532 |

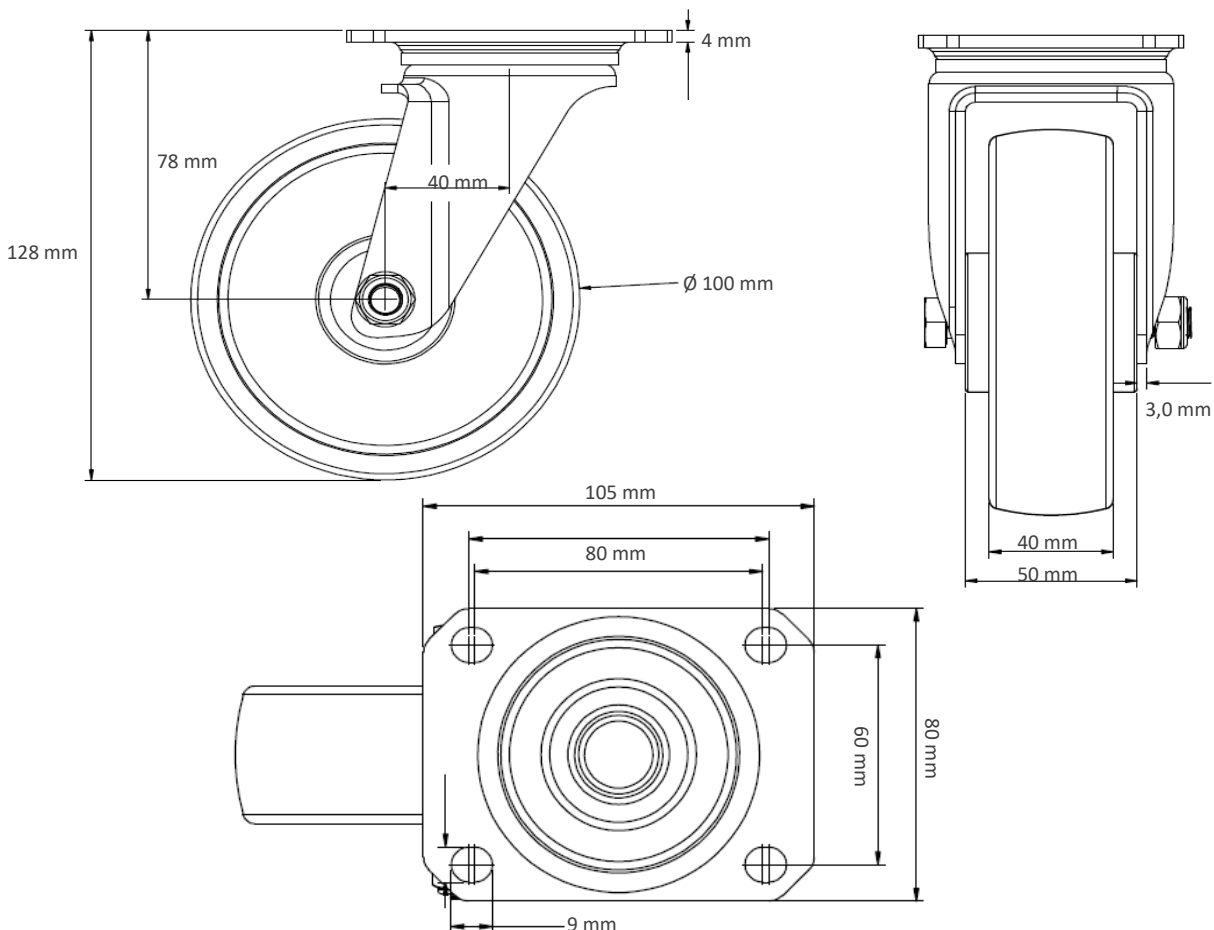
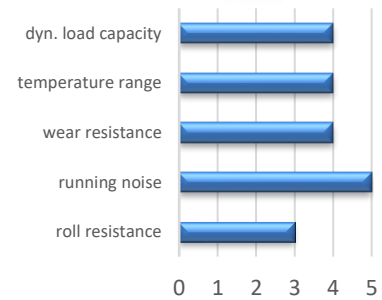

Deviation possible! All information is subject to change.