

Product Sheet



Item No. T I P 2 6 S C 100 R 4 E 2 Q 0 N

housing / data

housing type	swivel castor with total brake
series	CASCOO Innovation
fixing type	fixing plate
hole dimensions / hub width	80 x 60 mm / 42 mm
thickness of fixing / fork	2.50 mm / 2.00 mm
surface treatment	stainless steel



wheel / data

diameter	100 mm
wheel center	Polyamide black
wheel tread	elastic 65° Shore A grey
bearing	roller bearing (stainless steel)
threadguard	no separate threadguard
hub width	40 mm
axle diameter	M8
temperature range	-20°C - +80°C
dyn. load capacity	150 kg
test norm	DIN EN 12532

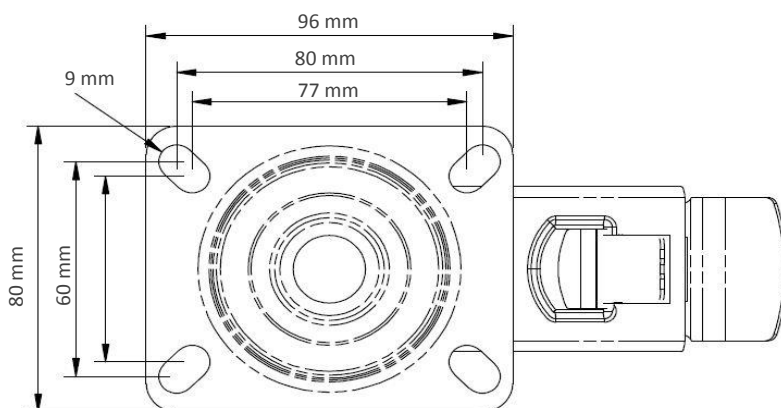
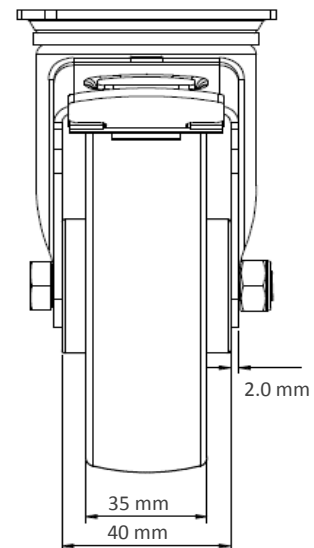
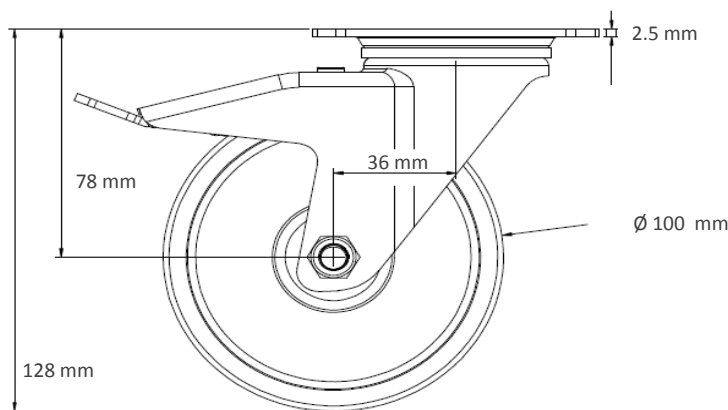
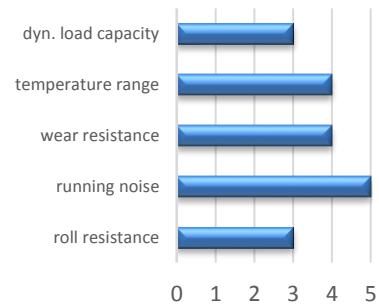

Deviation possible! All information is subject to change.