

Product Sheet



Item No. T I P 3 6 S C 125 N O N O L O N

housing / data

housing type	swivel castor with total brake
series	CASCOO Innovation
fixing type	fixing plate
hole dimensions / hub width	80 x 60 mm / 52 mm
thickness of fixing / fork	2.50 mm / 2.00 mm
surface treatment	stainless steel



wheel / data

diameter	125 mm
wheel center	Polyamide
wheel tread	Polyamide
bearing	plain bearing (stainless steel)
threadguard	no separate threadguard
hub width	50 mm
axle diameter	M8
temperature range	-40°C - +80°C
dyn. load capacity	200 kg
test norm	DIN: EN 12532

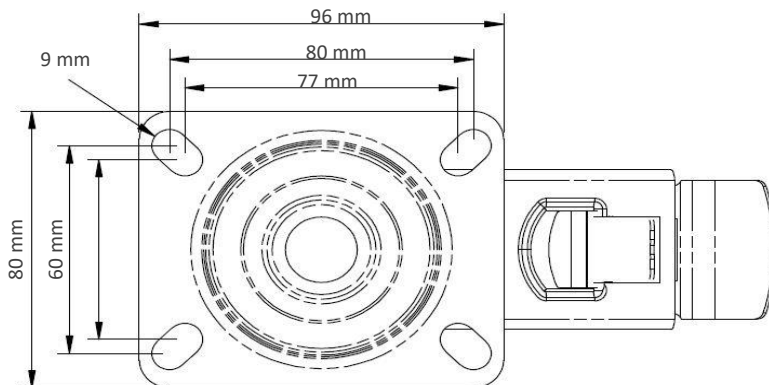
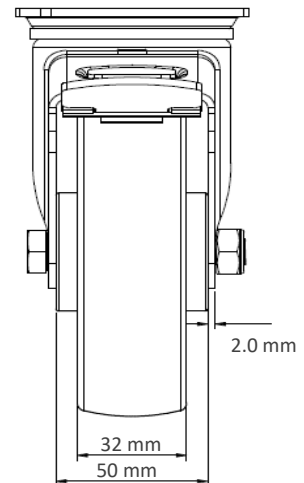
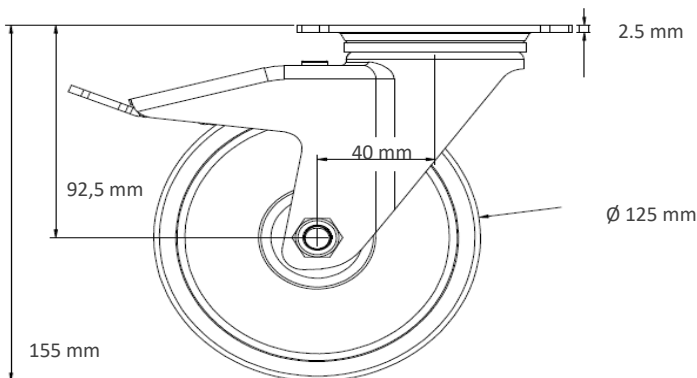
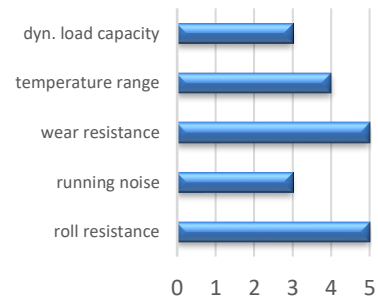

Deviation possible! All information is subject to change.