

Product Sheet



Item No. T I P 5 O S C 160 N 2 U 6 L 0 N

housing / data

housing type	swivel castor with total brake
series	CASCOO Innovation
fixing type	fixing plate
hole dimensions / hub width	105 x 80 mm / 60 mm
thickness of fixing / fork	2.75 mm / 2.50 mm
surface treatment	stainless steel



wheel / data

diameter	160 mm
wheel center	Polyamide grey
wheel tread	Polyurethane red
bearing	plain bearing (stainless steel)
threadguard	no separate threadguard
hub width	59 mm
axle diameter	M 12
temperature range	-40°C - +80°C
dyn. load capacity	300 kg
test norm	DIN: EN 12532

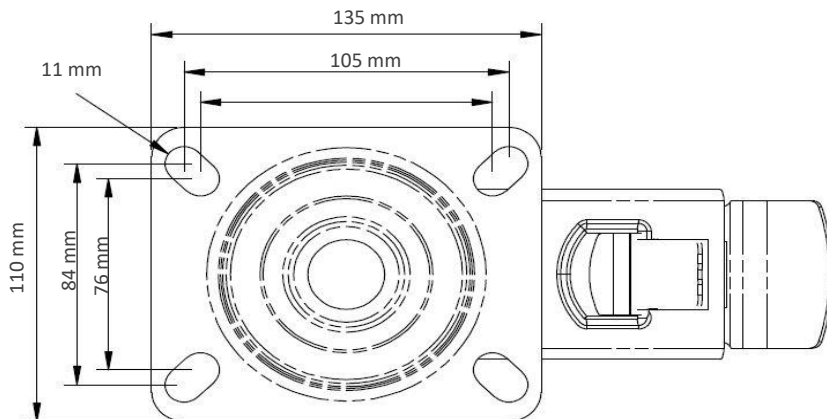
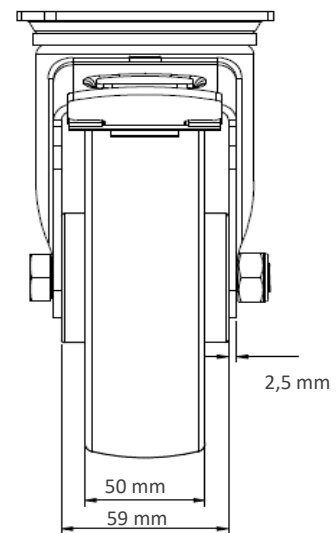
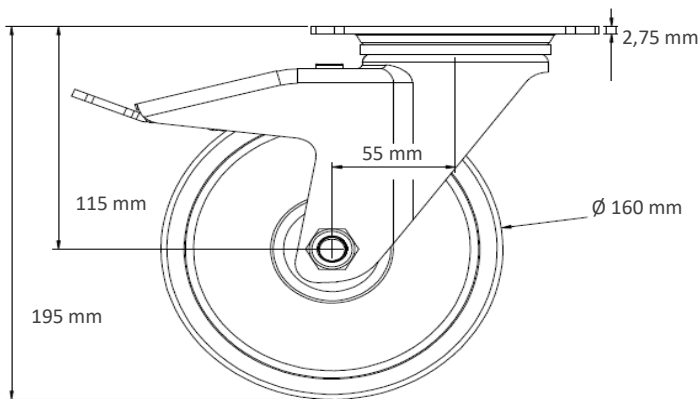
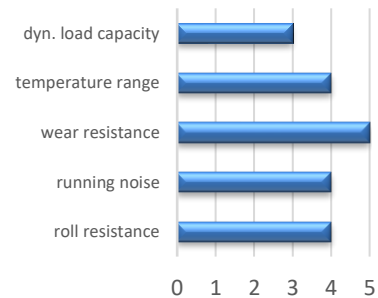

Deviation possible! All information is subject to change.