

Product Sheet



Item No. T Z P A 6 W 0 035 S W U 5 D 0 N

housing / data

housing type	swivel castor with total brake
series	compact castors
fixing type	fixing plate
hole dimensions / hub width	48/38 x 48/38 mm / 30 mm
thickness of fixing / fork	2.50 mm / 2.00 mm
surface treatment	galvanized blue zinc



wheel / data

diameter	35 mm
wheel center	steel rim
wheel tread	Polyurethane brown
bearing	double ball bearing
threadguard	no separate threadguard
hub width	30 mm
axle diameter	M 6
temperature range	-20°C - +60°C
dyn. load capacity	100 kg
test norm	DIN EN 12532

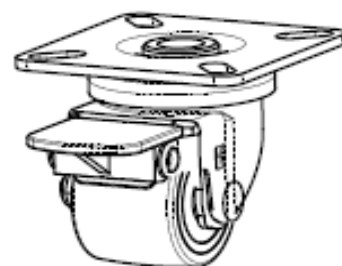
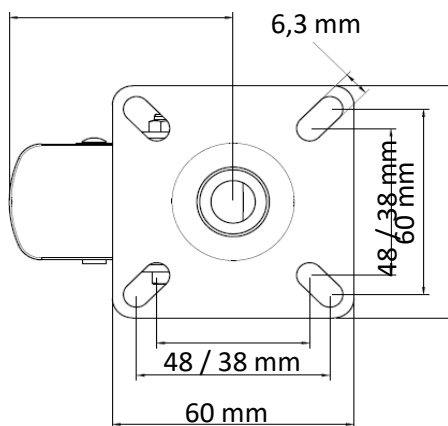
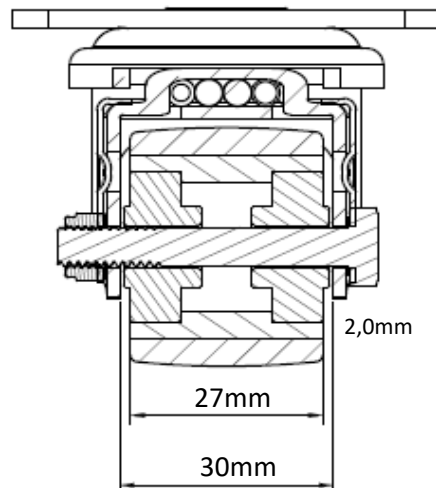
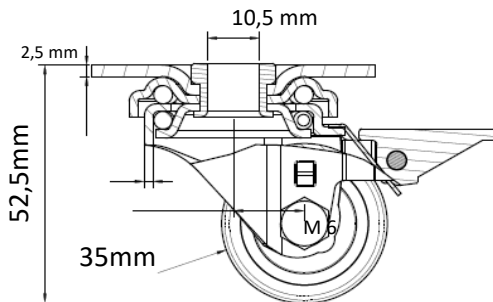

Deviation possible! All information is subject to change.